



Semi-knocked down floor cabinet

Models: PCRFCSKD27U80BK | PCRFCSKD32U80BK
PCRFCSKD37U80BK | PCRFCSKD42U80BK
PCRFCSKD45U100BK

Professional Series

Installation guide

1. Introduction

Thank you for purchasing the semi-knocked down (SKD) floor cabinets from Nexxt Solutions. Each floor unit is housed in a lockable heavy-gauge metal enclosure designed to accommodate any rack-mounted product such as modular network or voice switches, routers, telecommunication systems, electronic and other network devices. It features a tempered glass front door with a key-lock and four fans. This 31.50-inch deep cabinet is available with 27, 32, 37 or 42 rack spaces and a 39.3-inch deep cabinet of 45 rack spaces.

Main features

- 1540lb maximum load capacity
- Top and bottom access to cables
- Independently locking front and rear section
- Standard square-punched mounting rails for faster component loading

For support and to find out more about our complete solution, we invite you to visit us at nexxtsolutions.com.

2. Preliminary steps

- Prior to installing this product, you must read all instructions thoroughly.
- Keep these instructions handy in an easily accessible location for future reference.
- A clean, flat, level, protected floor area should be provided for cabinet assembly to prevent damage to parts.
- The installer will need to have the following items and tools available to assemble and install the cabinet. They are not included in the package.

1. Phillips screwdriver or power drill with the following bits
Phillips-head tip
Hex to square socket adaptor
2. 13mm hex socket
3. Pair of gloves
4. Long nose plier
5. Cleaning towel
6. 3mx2m mat or padded surface



3. Package content

Upon opening the boxes, make sure all the items listed below are included:

Box 1

Item	Qty
Top panel	1
Bottom panel/base	1
Side bar	4 (27U and 32U) 6 (37U, 42U and 45U)
Cable entry plate for bottom panel	4
Cable entry plate for frame	3
Removable side panel	2
Fan tray unit	1
Caster wheel	4
Support foot	4
Installation guide	1
Hardware and assembly kit	(see detailed content below)

Box 2

Item	Qty
Support frame	2
Perforated rail for device installation	4









Box 3







Item	Qty
Front tempered glass door	1
Rear mesh door	1
Side panel	2

Hardware and assembly kit content

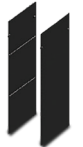

Item description	Dim.	Bag#	ID	Qty	Application
Phillips-head self-tapping screw	M4xL8	2	A	30	Cable entry plates, and side panel door stop
Phillips-head screw	M6xL12	3	B	24	Side bars and frame
Flange nut	M6	3	B	24	Side bars and frame
Phillips-head screw	M8xL12	1	C	16	Frame, top panel, bottom panel /base
Flange nut	M8	1	C	16	Frame, top panel, bottom panel /base
Phillips-head self-tapping screw	M5xL10	2	D	44	Caster wheels, side bars, fan tray unit and vertical profiles
Phillips-head self-tapping screw	M6xL12	2	E	24	Side bars and vertical profiles
Cage nut	M6	2	F	24	Side bars
Door pivot pin		4		2	Front and rear door
Flat metal washer		4		4	Front and rear door
Pivot pin plastic guide		4		4	Front and rear door
Side panel metal stop bracket		5		8	Side panels
Phillips-head screw	M6xL12	6	G	25	Installation screw set for your devices
Plastic washer	M6	6	G	25	Installation screw set for your devices
Cage nut	M6	6	G	25	Installation screw set for your devices
Front cam lock with key set		7		1	Front door
Rear and side door cam lock with key set		7		3	Rear door and side panels
Lock offset plate		7		4	Front, rear door and side panels
Pigtail grounding cable	16AWG	7		3	Grounding
Adjustable feet	M10xL68	7		4	To support complete unit
Caster wheels		7		4	To support complete unit



Components



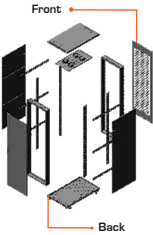







	Top and bottom panels		Caster wheels and adjustable feet
	Front and rear frames		Front cam lock with handle
	Side bars		Rear door and side panels cam lock
	Perforated mounting rails		Top and bottom cable entry panels



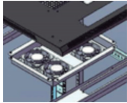





C1		Side panels		Door pivot pin and side panel metal stop bracket
D1		Rear mesh and front tempered glass doors		Flat metal washers
D2		Green/yellow pigtail grounding cables		Fan tray unit
D3		Lock offset plate		





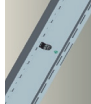

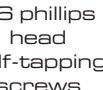

4. Installation procedure (recommended)

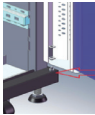

Step	Image	Required parts	Assembly steps
			<ul style="list-style-type: none"> The illustration provides an exploded view of all the enclosure components you are about to put together. Open the boxes and verify that all parts, hardware and accessories are included in the package. Inspect the cabinet components and identify each individual part to ensure proper assembly of the unit.
1		2 support frames (A1)	<ul style="list-style-type: none"> Identify both frames. Make sure to position front and back structures with the rows of square holes facing inward. It is recommended to lay down the frames on a mat or protected floor area to facilitate the assembly of the components required during this stage of the process.

Step	Image	Required parts	Assembly steps
2		1 bottom panel 4 cable entry plates for bottom panel 2 cable entry plates for frame 12 M4xL8 phillips-head self-tapping screws (A) 8 M8xL12 phillips-head screws 8 MB flange nuts (C)	<ul style="list-style-type: none"> Identify the bottom panel and cable entry plates. Place the front and rear frames on the bottom panel. Insert the M8xL12 phillips-head screws from the inside through the support frames and into the bottom panel. Secure both frames to the bottom panel from the outside using the supplied MB flange nuts. Proceed to install from the inside 2 of the longer cable entry plates on the frame openings using the M4xL8 phillips self-tapping screws. Position the 5 shorter cable entry plates on the bottom panel opening and attach each one from the inside using the M4xL8 phillips self-tapping screws.
3		4 caster wheels 16 M5xL10 phillips-head self-tapping screws (D) 4 adjustable feet	<ul style="list-style-type: none"> Identify the 2 caster wheels with brake mechanism to be installed in the front, and the 2 regular caster wheels which will be used in the back of the cabinet. The back section is the one located closest to the bottom cable entry plates. Align the holes on the wheel plate with the ones on the bottom panel. Fix the wheels to the base using the supplied M5xL10 phillips screws. Repeat the same process until all 4 wheels are installed. It is usually recommended to attach the feet at this stage, but you may consider screwing them not to their full extension. In that way, the wheels can remain fully operational so you can still roll or turn the cabinet around as needed while working on it.
4		1 top panel 8 M8xL12 phillips-head screws 8 MB flange nuts	<ul style="list-style-type: none"> Identify the top panel and two cable entry plates. Place and align the top panel over the front and back frames, as illustrated in this step. The section with the grille must be facing the front side of the cabinet. Insert the M8xL12 phillips-head screws from the outside, through the top panel and support frames. Thread a nut onto each screw to hold the panel and frames together.

Step	Image	Required parts	Assembly steps
5		<p>1 cable entry plate</p>  <p>2 M4xL8 phillips-head self-tapping screws</p> 	<ul style="list-style-type: none"> Place the remaining two cable entry plates on top of the upper access holes located on the top panel, so as to cover them from the inside. Align the holes on each plate with the ones on the frame, and fix them from the inside using the supplied M4xL8 phillips-head self-tapping screws.
6		<p>Fan tray unit</p>  <p>2 M5xL10 phillips-head screws</p> 	<ul style="list-style-type: none"> Identify the fan tray unit. Position the tray so as to have the power cord and power switch facing towards the back of the cabinet. The voltage selector should be facing the front of the cabinet. Mount the unit in the roof inside the cabinet, using the supplied M5xL10 phillips head screws. Insert the screws also from the inside, through the fan tray and into the holes of the front and back frames respectively. After the fan tray is installed, you may put the cabinet back to its standing position.
7		<p>4 or 6 side bars</p>  <p>16 or 24 M6 flange nuts</p>  <p>16 or 24 M6xL12 phillips-head screws and M6 plastic washers</p>  <p>16 or 24 M5xL10 self-tapping phillips-head screws</p> 	<ul style="list-style-type: none"> Identify the side bars. Count up to the third and fourth square holes from the bottom and upper ends of the frames and insert a M6 flange nut in each opening with the tabs facing inward. Define the middle of the cabinet to install the center bars. Find a point near the lock and insert two M6 with the tabs facing inward. Make sure to position the bars so that the hook at each end is inserted in the corresponding slots on the front and rear frames. Insert the M6xL12 phillips-head screws from the inside through the side bar holes and into the flange nuts installed in the frames. Then install the self-tapping screws to secure the side supports to the thread holes on the frames.

Step	Image	Required parts	Assembly steps
8		<p>16 or 24 M6 cage nuts</p>  <p>4 perforated mounting rails</p>  <p>16 or 24 M6xL12 phillips-head screws</p>  <p>16 or 24 M6 plastic washers</p> 	<ul style="list-style-type: none"> On the already installed side bars, count up the second and third square holes from the front and rear ends and insert one M6 cage nut in each one, with the tabs facing inward. Repeat this procedure until all 16 or 24 cage nuts are installed. Next, identify the 4 vertical perforated mounting rails. Position the perforated mounting rails so as to have from high to low the number of rack units stamped on each column. In addition, the row of numbers on each vertical rail must be facing each other, on the front and rear sections of the unit. Proceed to insert the M6xL12 phillips-head screws and plastic washers from the inside through the vertical mounting rails and into the cage nut installed in each side bar. Tighten all 16 or 24 nuts to secure the rails to the side bars.
9		<p>8 side panel metal stop brackets</p>  <p>16 phillips head self-tapping screws</p> 	<ul style="list-style-type: none"> Identify the metal stop brackets. Place the stop brackets on the front and rear frames, right below the upper side bar. Attach all 8 brackets to the structure using the phillips head self-tapping screws.
10		<p>2 side panels</p> 	<ul style="list-style-type: none"> Next, identify the 2 side panels. Both are identical for this model. Place bottom section of each side panel over the outer edge of the cabinet base. Slide the plastic retaining latches on both sides of the panel to their unlock position. Push side panels against the support frames and release the plastic retaining latches so as to re-engage them to their locked position. <p>Note: Please install the cam locks in the upper opening of the side panels.</p>

Step	Image	Required parts	Assembly steps
11		<p>1 door pivot pin</p>  <p>2 flat metal washers</p>  <p>1 rear mesh door</p> 	<ul style="list-style-type: none"> • Identify the rear door and pivot pin. • Insert a flat metal washer in the short end of the door pivot pin. • Then fit the pin into the hole found on the right side of the bottom panel. • Put another washer on the exposed tip of the pin. Next, position the door and carefully lower it to engage the pivot pin below. • Pull down the spring lock located on the upper right section of the door and release it into the hinge hole in the enclosure.
12		<p>1 rear cam lock with offset plate</p> <p>1 set of keys</p>	<ul style="list-style-type: none"> • Identify the rear cam lock and key set. • Start by unfastening the screw located on the back end of the lock. Take apart the metal washer, lock hook plate and nut. The white plastic washer around the lock is the only part that must not be removed. • Proceed to insert the cam lock with the plastic washer into the door opening from the outside. When doing so, make sure the lock is in its unlocked position. • First, replace the nut you just removed to fasten the lock from the inside of the door. • Continue to replace the lock offset plate, washer and the screw. • After making sure the lock offset plate is on its vertical (fully open) position, tighten the screw to secure the lock assembly in place. • Use the keys to test the lock and verify that the latching mechanism is working properly.
13		<p>1 door pivot pin</p>  <p>2 flat metal washers</p>  <p>1 front tempered glass door</p>	<ul style="list-style-type: none"> • Identify the front tempered glass door and pivot pin. • Insert a flat metal washer in the short end of the door pivot pin. • Then fit the pin into the hole found on the right side of the bottom panel. • Put another washer on the exposed tip of the pin. Next, position the door and carefully lower it to engage the pivot pin below. • Pull down the spring lock located on the upper right section of the door and release it into the hinge hole in the enclosure.

Step	Image	Required parts	Assembly steps
14		<p>1 front cam lock with handle and offset plate</p> <p>1 set of keys</p>	<ul style="list-style-type: none"> • Identify the front cam lock and key set. • Start by unfastening the two screws attaching the exterior plate of the lock. • Take apart the screw, stop cam washer, lock offset plate and exterior back plate. The black rubber seal around the lock remains assembled. • Proceed to insert the cam lock into the door opening from the outside. • First, replace the exterior back plate by screwing it to the lock assembly from the inside, using the two screws you just removed. • Next, replace the stop cam washer, followed by the offset plate and the screw from the inside of the door. • When installing the stop cam washer, you have to make sure to align the wings in such a way that they are parallel to the offset plate in the lock position. • After making sure the lock offset plate is on its vertical (fully open) position, tighten the screw to secure the lock assembly in place. • To open the door, push the lock in, pull the recessed handle out and rotate it 90° counter-clockwise to unlock the latch. To close it, turn the handle clockwise to engage the latch and push it back to its center position. • Use the keys to test the lock and verify that the locking mechanism is working properly.
15		<p>4 green/yellow pigtails</p> 	<ul style="list-style-type: none"> • Identify the green/yellow pigtail grounding cables. • Locate the grounding copper studs on the door, side panel and base found in the front section of the cabinet, and also the studs on the door, side panel and base found in the rear section of the unit. • Unfasten the nut from each stud and remove one of the two copper washers. • Connect one end of the pigtail grounding cable to the enclosure stud, and the other end, to the stud located on the door or side panel. • Replace the copper washer you just removed and screw the nut back to attach both ends of the pigtail. • Repeat the same procedure until the front and rear doors, and the panels on both sides are properly grounded. • With the power switch set to off, plug the fan tray unit cord into a wall outlet. • The enclosure assembly is now complete.