

Horizontal cable management 19in/ 1U and 2U , duct type

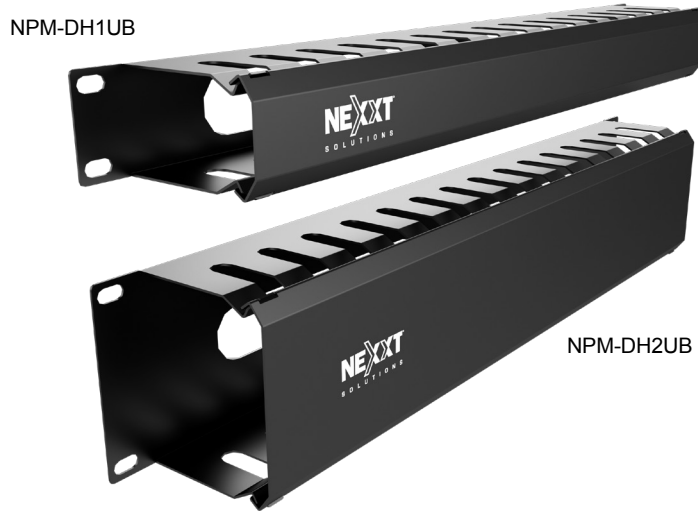

Nexxt Solutions horizontal Duct cable management is designed to be mounted onto any standard 19-inch EIA rack or cabinet. Fingers have smooth edges and are widely spaced to give additional cable support, also allowing terminated wires to be installed, removed or rerouted easily. Its innovative cover provides full access to cables, while improving the appearance of panels by keeping small and large bundles of cords neatly organized.

- Follows ANSI/TIA/EIA-568 C.2 manufacturing standards
- One layer of electrostatic coating protects it against humidity, rust, scratches, peeling, strong acid and alkaline erosion.
- Black epoxy-polyester hybrid powder paint.
- For indoor use only, in environmentally controlled areas, may not be used outdoors, in industrial or harsh environments or in plenum spaces.

1U

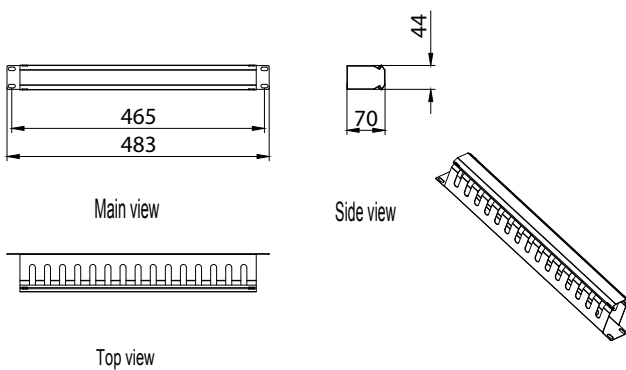

2U

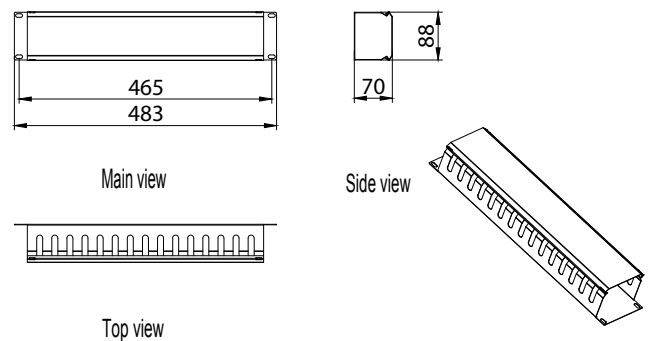

Horizontal cable management 19in/ 1U and 2U , duct type

Product specifications

		Cable management characteristics	
Bracket color	Black varnish paint (RAL 9005)		
Effective U space	1U	2U	
Mounting type	19in horizontal rack mounted		
Access type	Top/bottom/rear and both sides		
Front/rear mounting option	Back to back		
Frame material	SPCC*, 1.0mm thickness		
Duct cover material	SPCC*, 1.0mm thickness		
Duct cover type	Detachable		
No. of cable slots	30 total (15 top + 15 bottom)		
No. of rear oval slots	2	2	
		Dimensions	
Overall height	70mm	83mm	
Overall width	483mm		
Overall depth	42mm	70mm	
Duct cover width	63mm	76mm	
Rear oval slot height	27mm		
Rear oval slot width	155mm		
Cable slot width	11mm		
	4 sets of cage nuts		
		Certifications and standards	
International standards	Comply with ANSI/EIA-ECA-310-E; DIN41491:PART1.IEC297-2; DIN41494:PART7; GB/T3047.2-92 standard; compatible with ETSI standard		
		Miscellaneous	
MPN	NPM-DH1UB	NPM-DH2UB	
UPC	798302036543	798302036550	
Labeling	NEXXT SOLUTIONS		
Packaging	Carton box		
Cu.ft.	495x80x50mm	485x95x85mm	
Warranty	Five-year limited**		

*SPCC: Commercial grade, cold rolled steel sheets.

** For warranty details, please visit www.nexxtsolutions.com/warranty

